



**RETENTION CABLE**  
**Installation Instructions Van:**  
**VNFD92ECXT65**

**FORD ECONOLINE EXT**  
**138" WHEELBASE**  
1992-2014

Watch short installation videos at [www.decked.com/video](http://www.decked.com/video) | Register your system at [www.decked.com/warranty](http://www.decked.com/warranty)

**FOLLOW US:**      **@DECKEDUSA | #DECKEDUSA**

VERSION 5

DECKED.COM | 208.806.0251

# REINFORCEMENT BRACKET AND RETENTION CABLE INSTALLATION

This view is to orient yourself to the vehicle, the DECKED System installed using the installation procedures that came with your system, and how the van cables should appear when the cable installation process is complete.

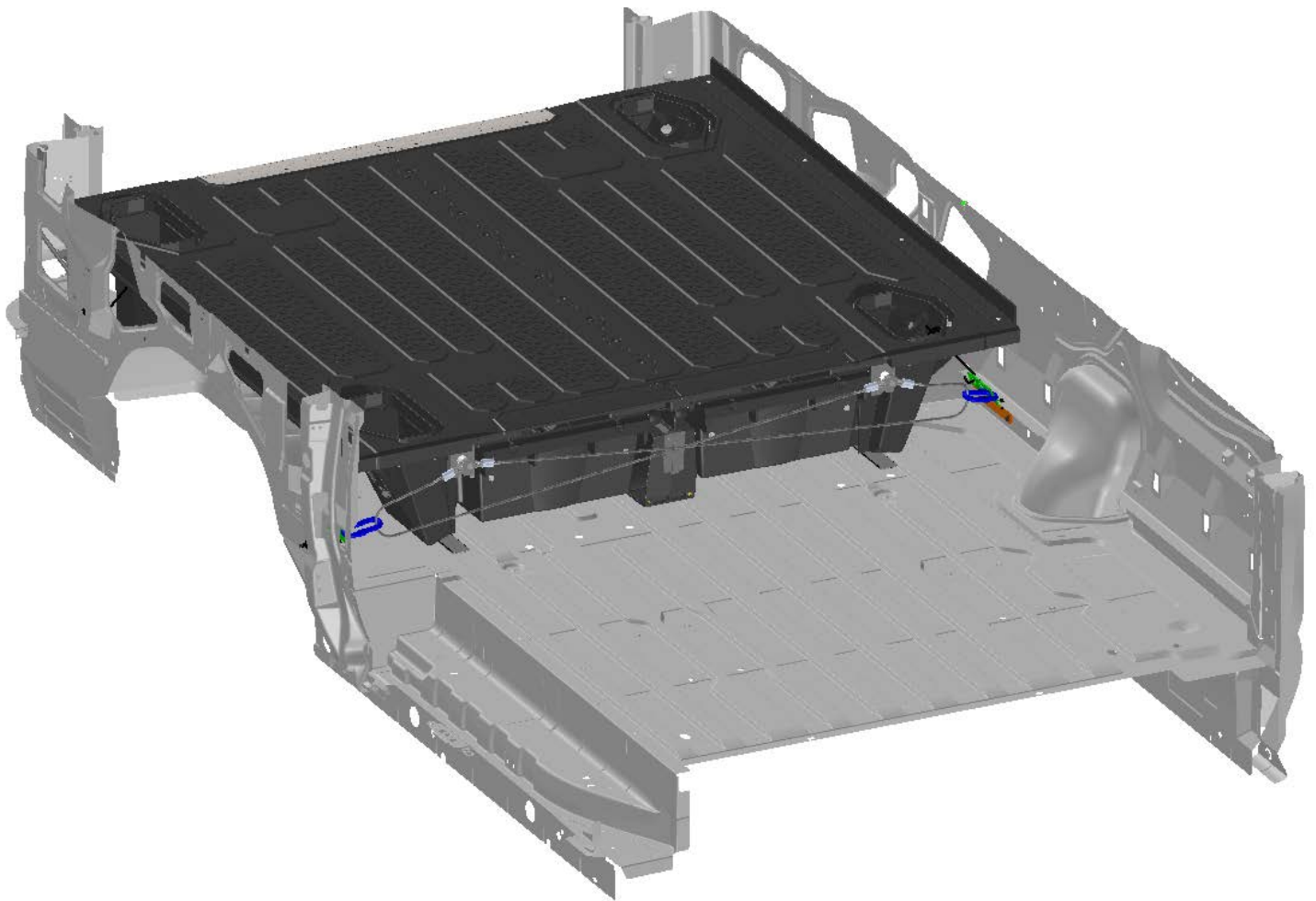

# REINFORCEMENT BRACKET INSTALLATION

Reinforcement bracket - RH location

Reinforcement bracket - LH location

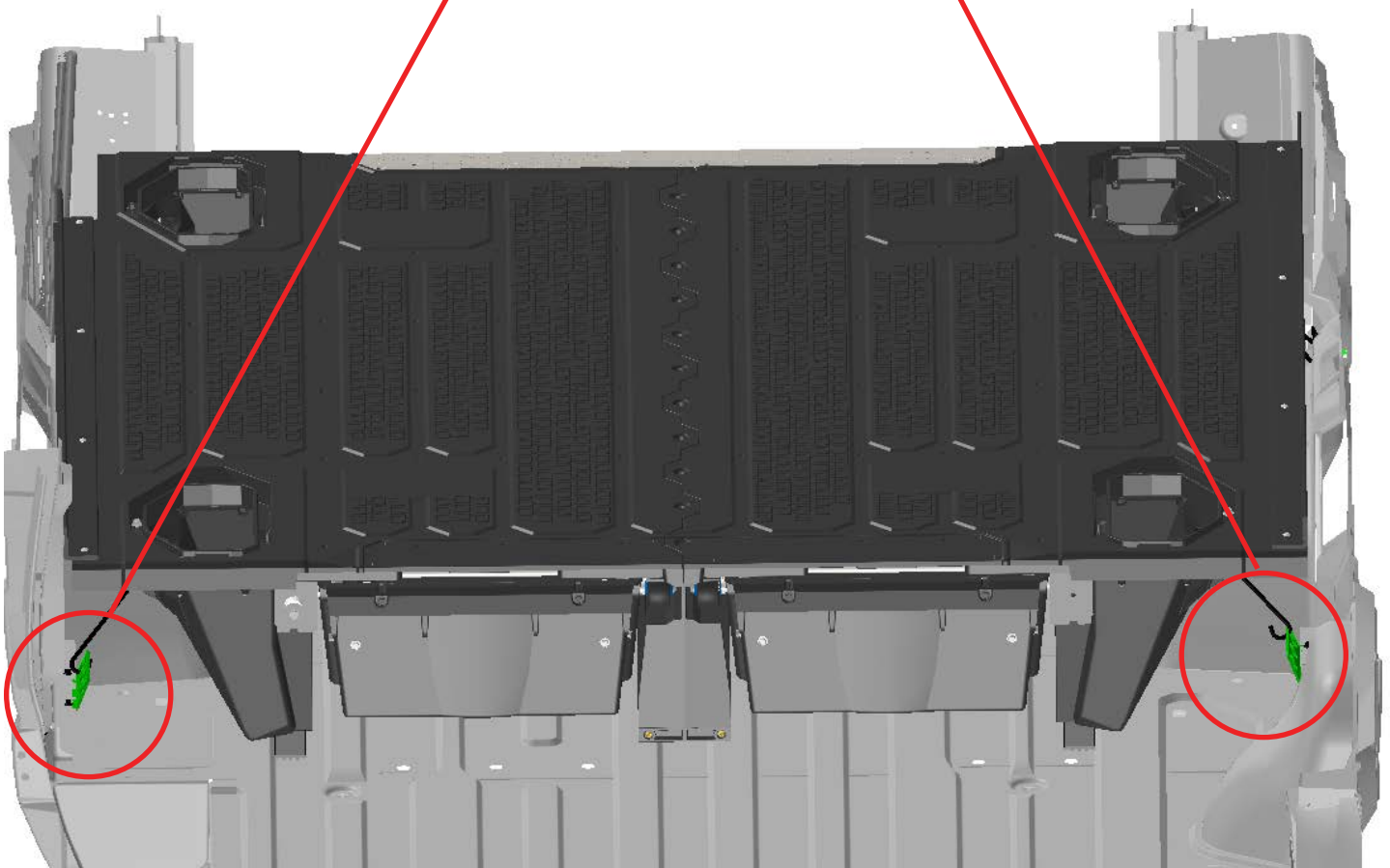

# REINFORCEMENT BRACKET INSTALLATION

## Reinforcement Bracket Installation – Step #1 –

- Referencing 1st image below, remove two nuts securing the tie down bracket (shown in green).
- Referencing 2nd image below, align reinforcement bracket (shown in orange); **BAG VAN CABLE KIT**, with underside of tie down bracket and locate against underside of vehicle flange and against mounting surface, using bolts for location. Temporarily secure with nuts previously removed.
- Mark centers of three holes with marking pen.
- Remove bolts, nuts and mounting brackets.

tie down bracket

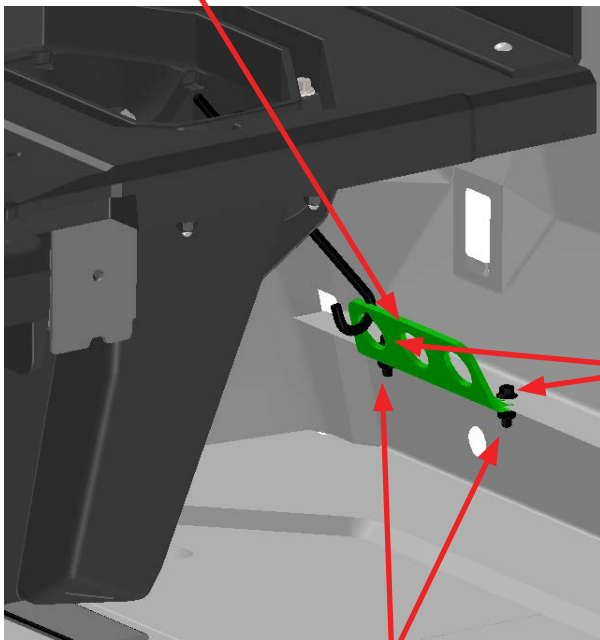

remove nuts

tie down bracket

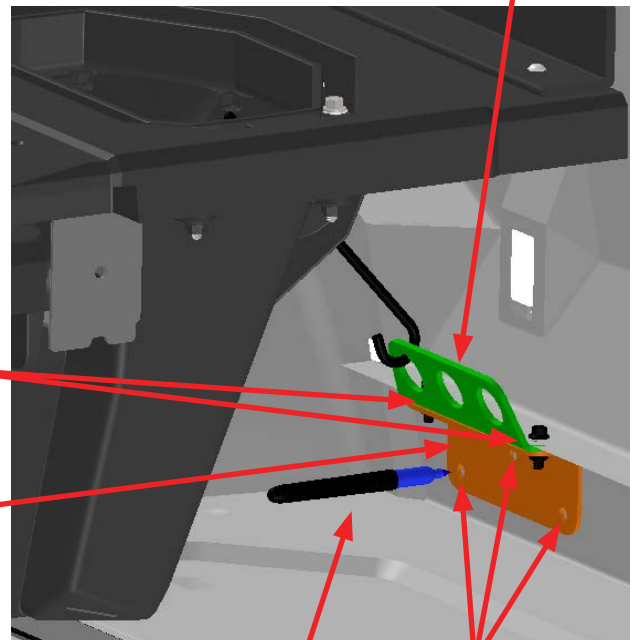

bolts

reinforcement  
bracket

marking pen

mark 3 holes

LH side reinforcement bracket shown

# REINFORCEMENT BRACKET INSTALLATION

## Reinforcement Bracket Installation – Step #2 –

- Using marked hole centers, drill (3) .38” holes.
- Insert plus nut; **BAG VAN CABLE KIT**, into one of the three holes while holding with installer wrench.
- Tighten bolt head with a wrench or ratchet until plus nut is fully crimped.
- Unthread plus nut tool and install plus nuts in two remaining holes.
- Install tie down bracket and reinforcement bracket. Secure all fasteners to 53 in-lbs.
- Repeat process steps for installation of RH side reinforcement bracket.

**RECOMMENDED TORQUE:**  
Secure all fasteners to 53 in-lbs.

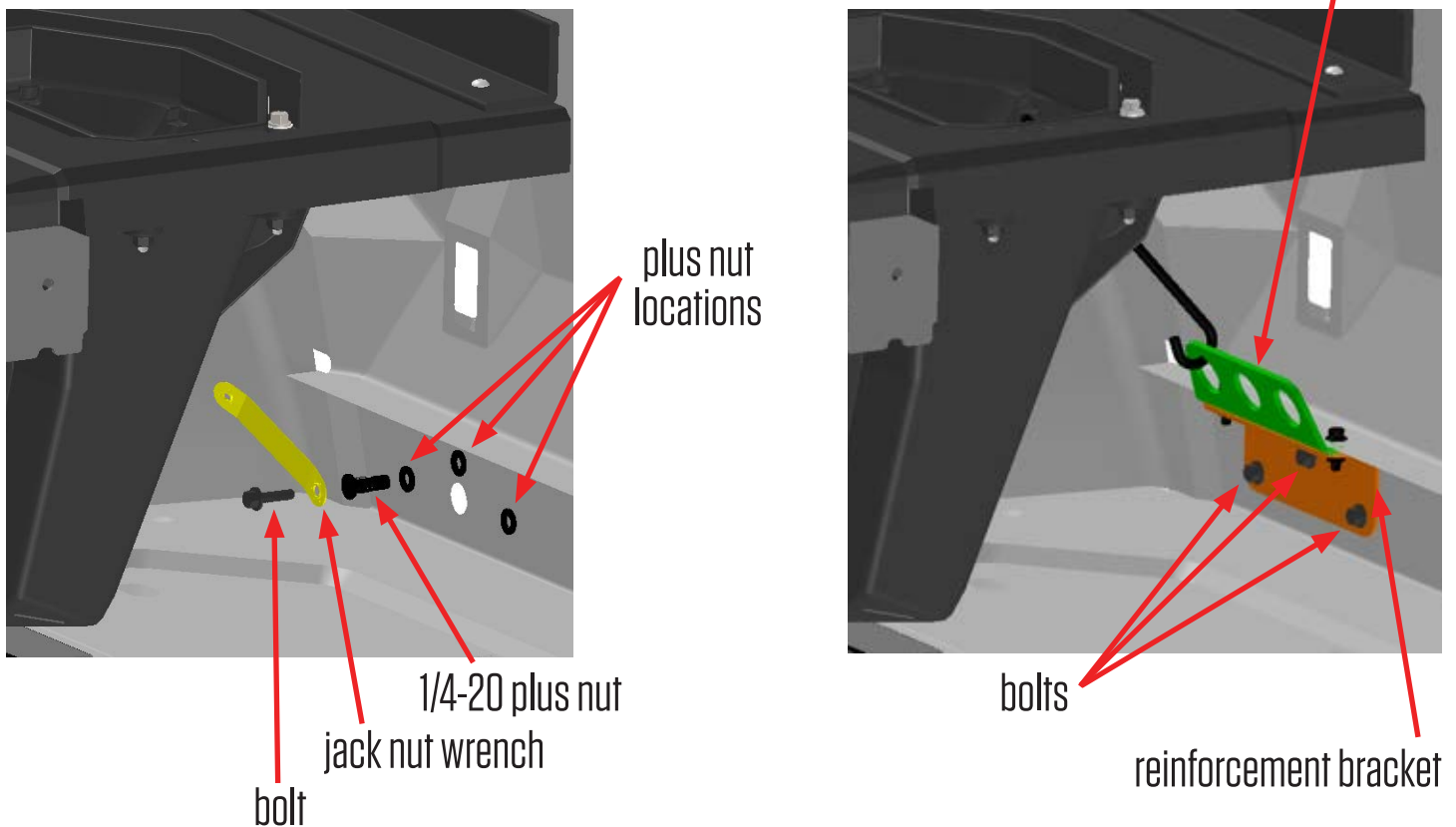

LH side reinforcement bracket shown

# RETENTION CABLE INSTALLATION

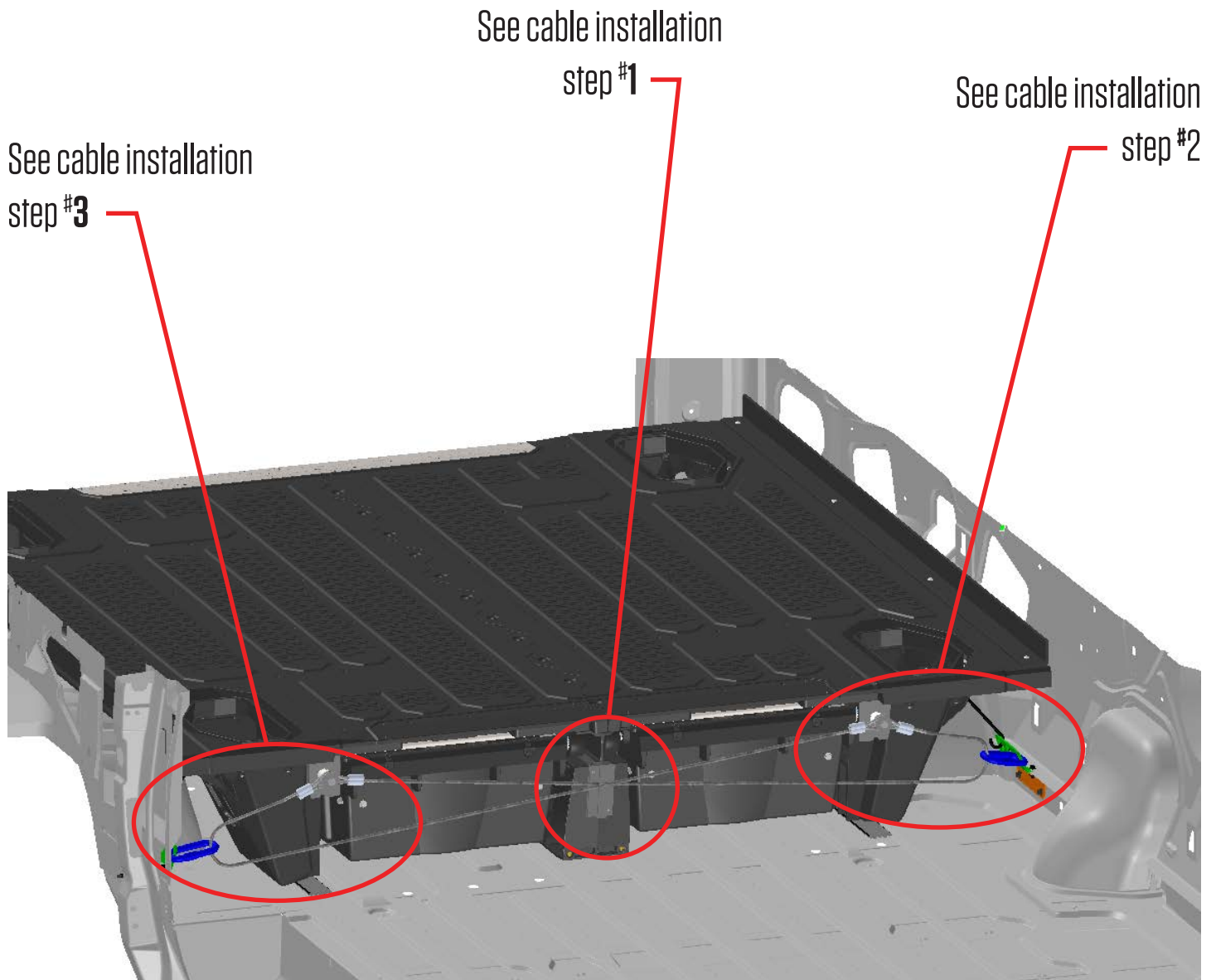

# RETENTION CABLE INSTALLATION

## Cable Installation – Step #1 –

- Center cable standoff to center vert and align top edge of standoff to bottom of drawer wheel channel.
- Run two #8 self-tapping screws, diagonally oriented as shown in image below, thru cable standoff and into center vert; **BAG VAN CABLE KIT**.

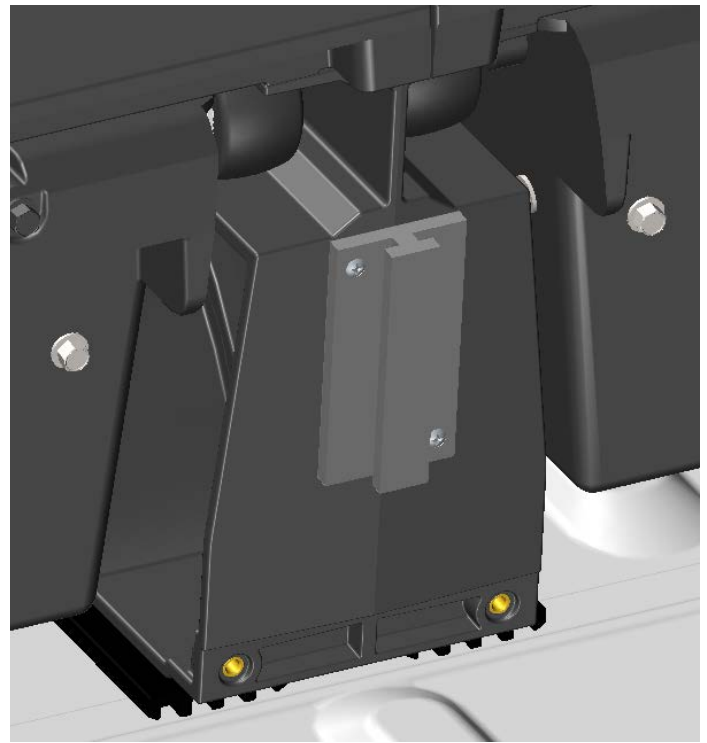
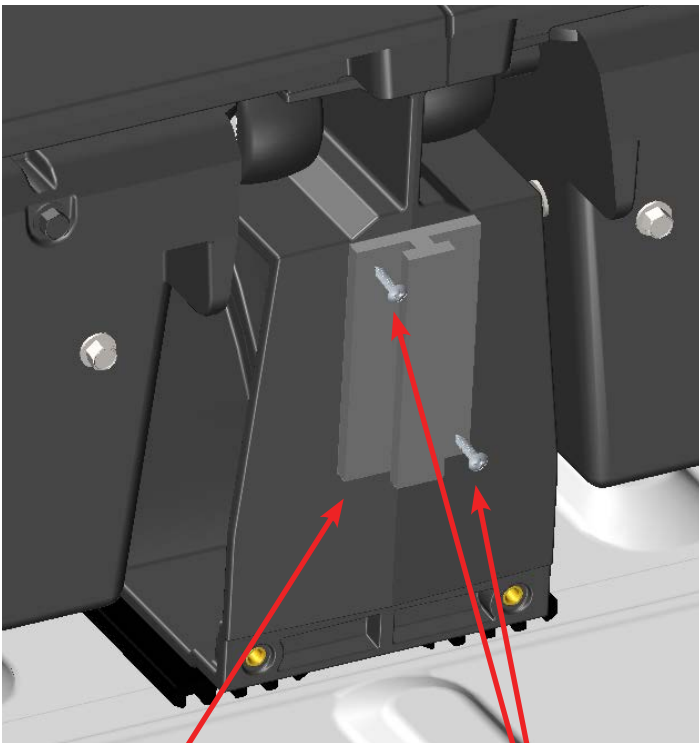

cable standoff

#8 self tapping screws

# RETENTION CABLE INSTALLATION

## Cable Installation – Step #2 –

Please note: the cables are of different lengths and marked LH & RH. The LH cable is longer.

- Loosen connecting link nut (shown in blue in assembled view); **BAG VAN CABLE KIT**, and install through forward hole in mounting bracket (shown in green in assembled view). Tighten connecting link nut securely.
- Starting on the driver side of the vehicle, loop LH cable eye thru connecting link (shown in blue in assembled view); **BAG VAN CABLE KIT**.
- Assemble LH and RH cable ends in the order depicted in the exploded view image, i.e. bolt thru washer, then thru RH cable eye and then LH cable eye, then thru 1 1/2" steel spacer and the thru 3/4" nylon spacer, thru hole in C-channel end plate and into nut; **BAG VAN CABLE KIT**.

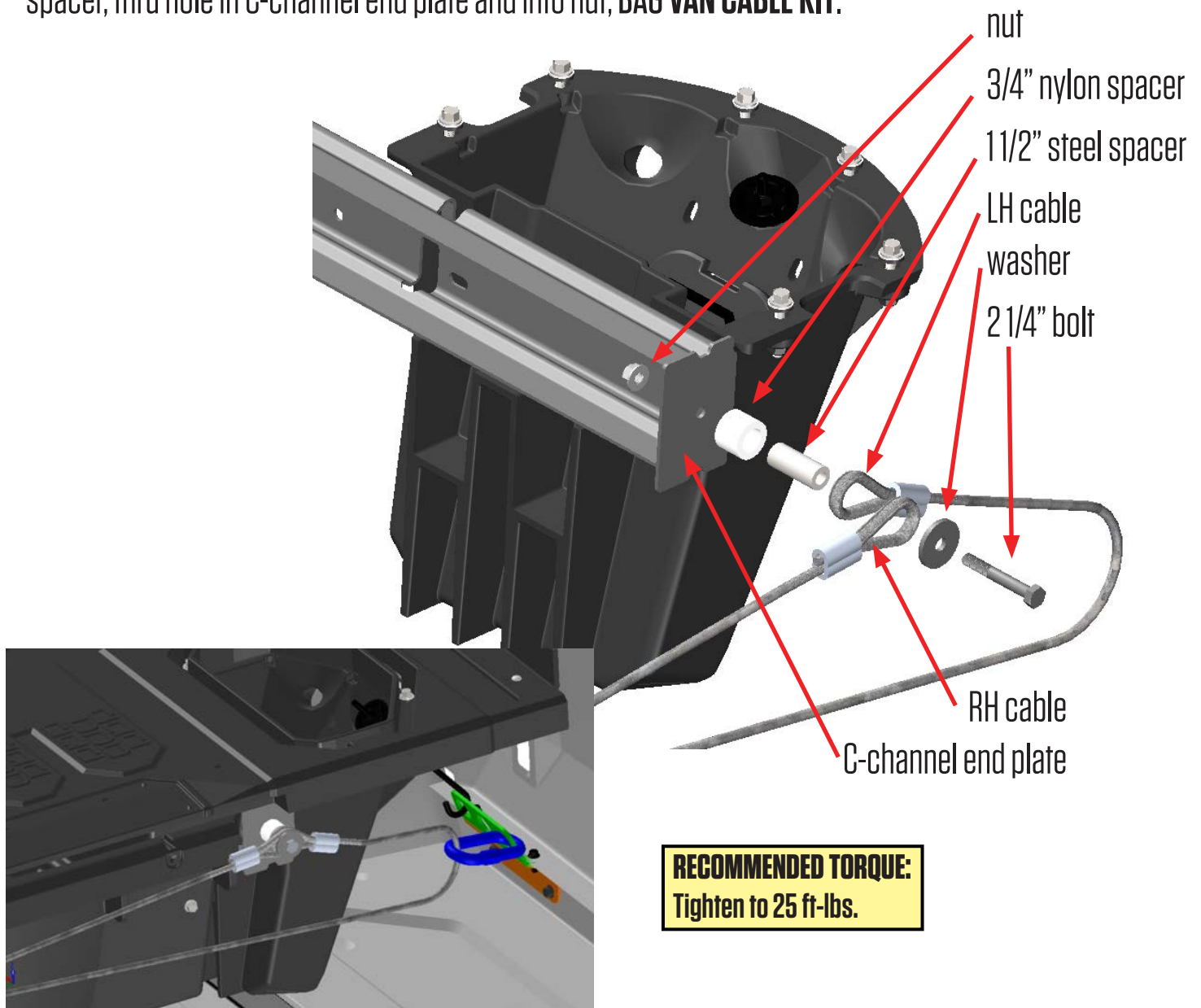



# RETENTION CABLE INSTALLATION

Enlargement of LH cable assembly attachment to connecting link (blue).

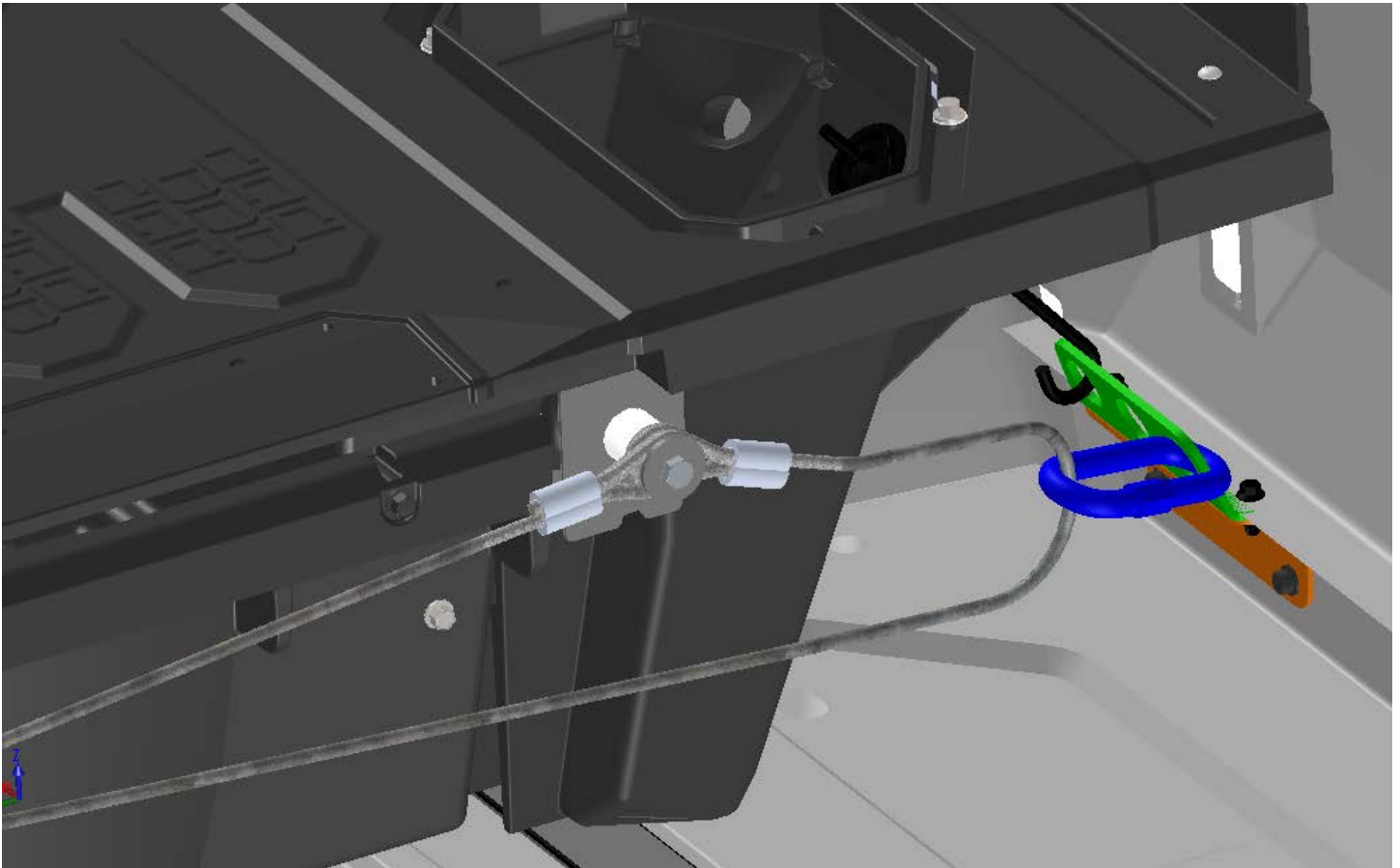
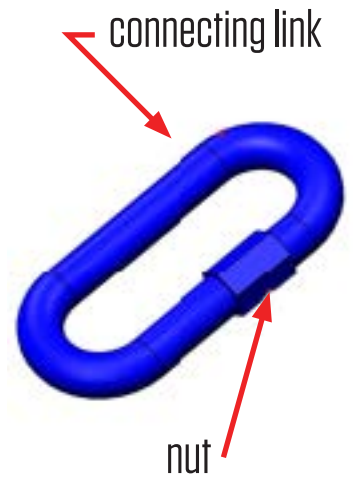

# RETENTION CABLE INSTALLATION

## Cable Installation – Step #3 –

Please note: the cables are of different lengths and marked LH & RH. The LH cable is longer.

- Loosen connecting link nut (shown in blue in assembled view); **BAG VAN CABLE KIT**, and install through forward hole in mounting bracket (shown in green in assembled view). Tighten connecting link nut securely.
- Starting on the driver side of the vehicle, loop RH cable eye thru connecting link (shown in blue in assembled view); **BAG VAN CABLE KIT**.
- Assemble LH and RH cable ends in the order depicted in the exploded view image i.e. bolt thru washer, then thru LH cable eye and then RH cable eye, then thru 1 1/2" steel spacer and the thru 3/4" nylon spacer, thru hole in C-channel end plate and into nut; **BAG VAN CABLE KIT**.

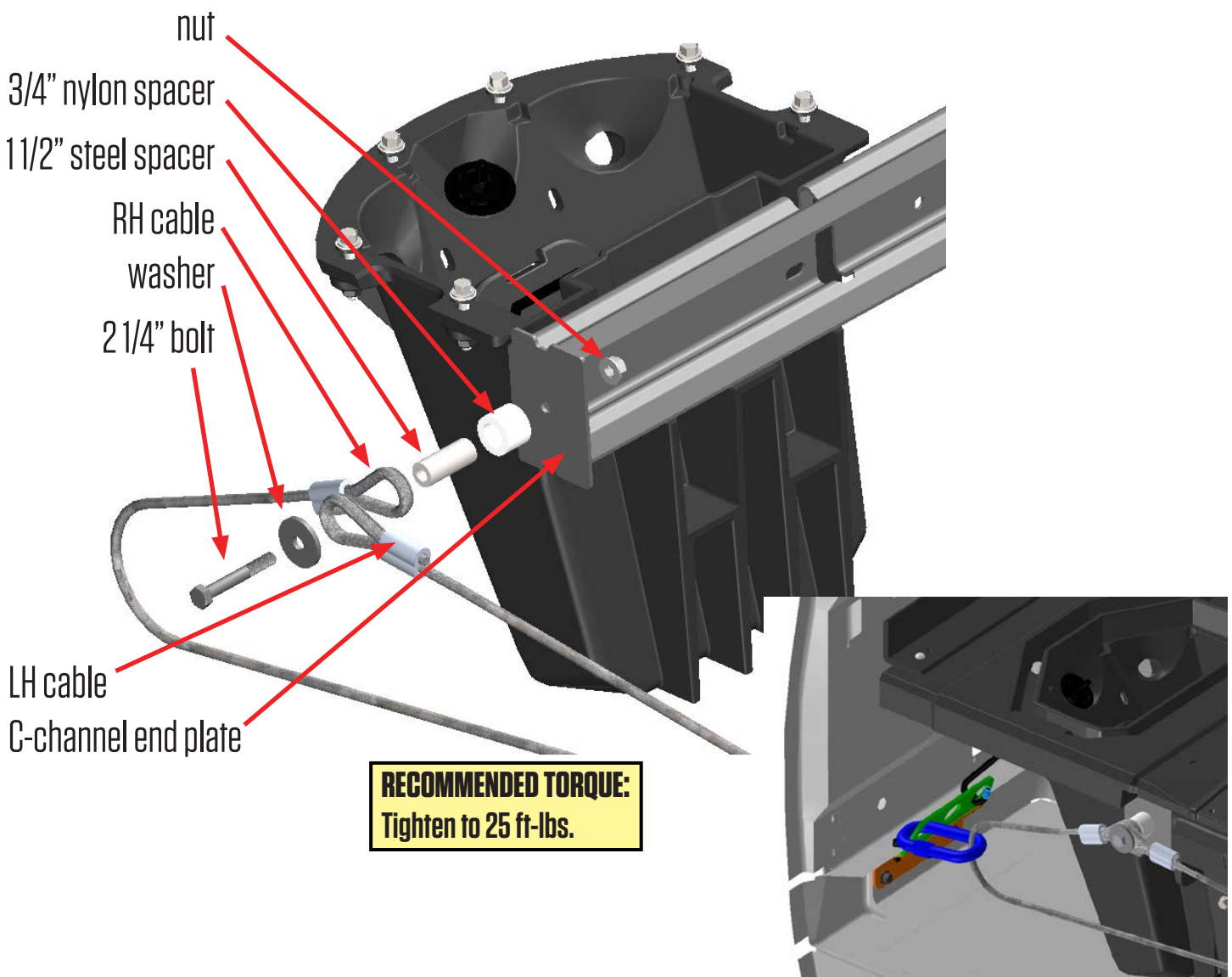

# RETENTION CABLE INSTALLATION

Enlargement of RH cable assembly attachment to connecting link (shown in blue).

