



RETENTION CABLE
Installation Instructions Van:
VNGM96EXSV55

EXPRESS/SAVANNA
135" WHEELBASE
1996-CURRENT

Watch short installation videos at www.decked.com/video | Register your system at www.decked.com/warranty

FOLLOW US: 



@DECKEDUSA | #DECKEDUSA

VERSION 5

DECKED.COM | 208.806.0251

RETENTION CABLE INSTALLATION

This view is to orient yourself to the vehicle, the DECKED System installed using the installation procedures that came with your system, and how the van cables should appear when the cable installation process is complete.

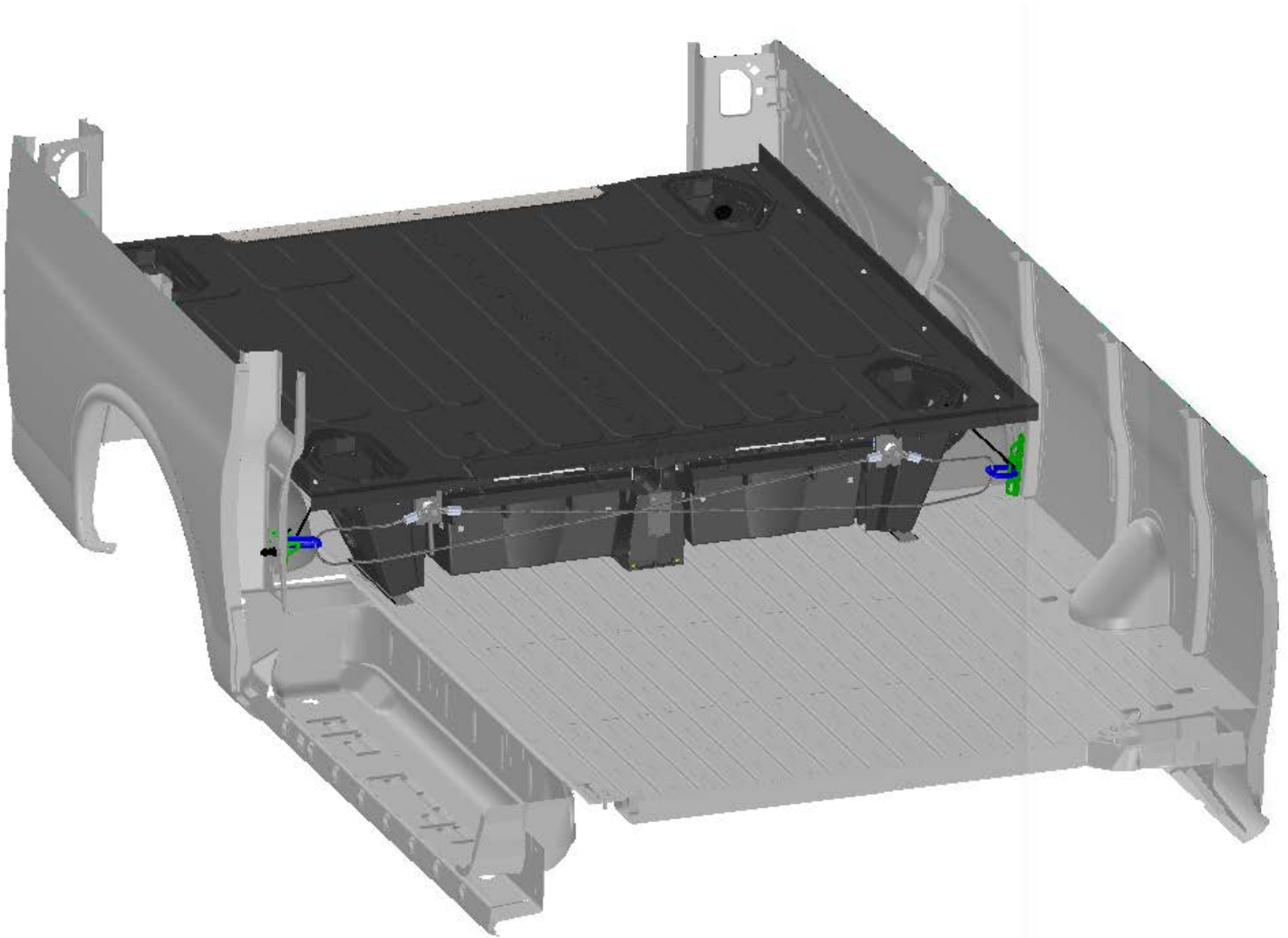

RETENTION CABLE INSTALLATION

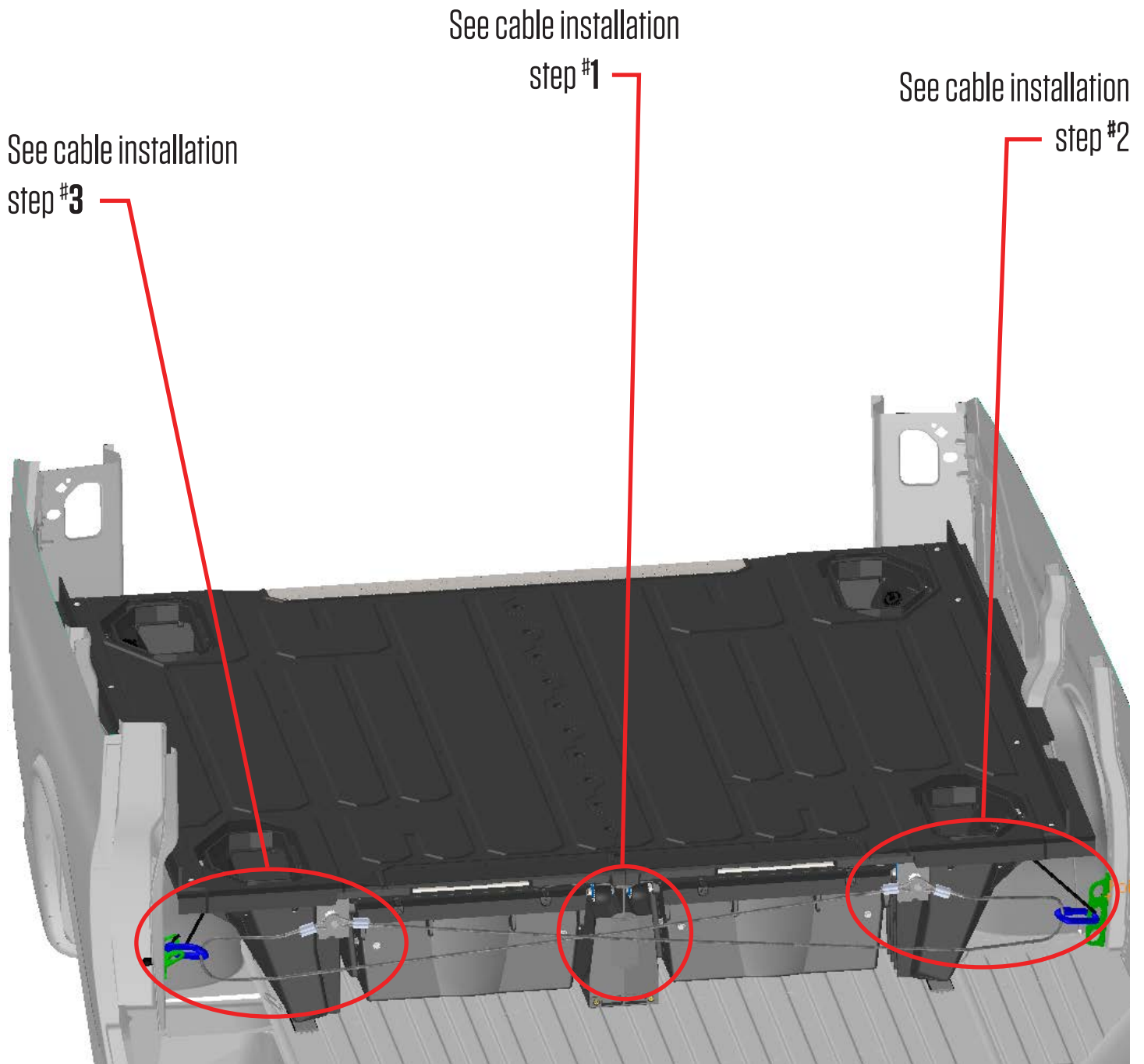

RETENTION CABLE INSTALLATION

Cable Installation – Step #1 –

- Center cable standoff to center vert and align top edge of standoff to bottom of drawer wheel channel.
- Run two #8 self-tapping screws, diagonally oriented as shown in image below, thru cable standoff and into center vert; **BAG VAN CABLE KIT**.

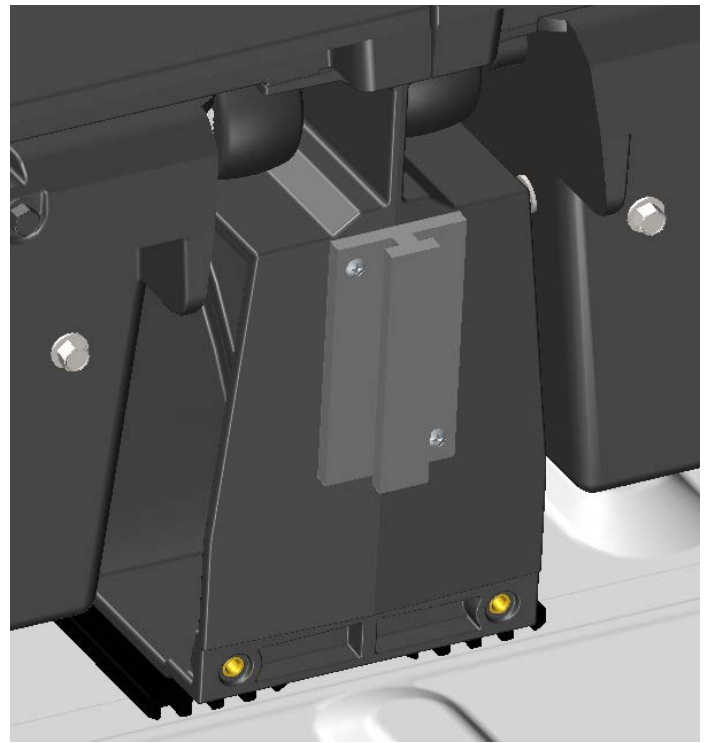
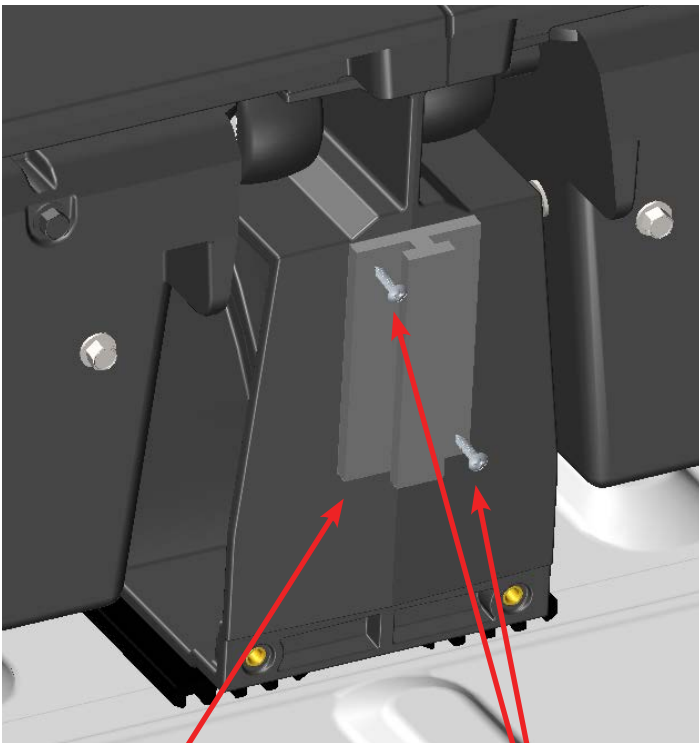

cable standoff

#8 self tapping screws

RETENTION CABLE INSTALLATION

Cable Installation – Step #2 –

Please note: the cables are of different lengths and marked LH & RH. The LH cable is longer.

- Loosen connecting link nut (shown in blue in assembled view); **BAG VAN CABLE KIT**, and install through center hole in mounting bracket (shown in green in assembled view). Tighten connecting link nut securely.
- Starting on the driver side of the vehicle, loop LH cable eye thru connecting link (shown in blue in assembled view); **BAG VAN CABLE KIT**.
- Assemble LH and RH cable ends in the order depicted in the exploded view image, i.e. bolt thru washer, then thru RH cable eye and then LH cable eye, then thru 1 1/2" steel spacer and the thru 3/4" nylon spacer, thru hole in C-channel end plate and into nut; **BAG VAN CABLE KIT**.

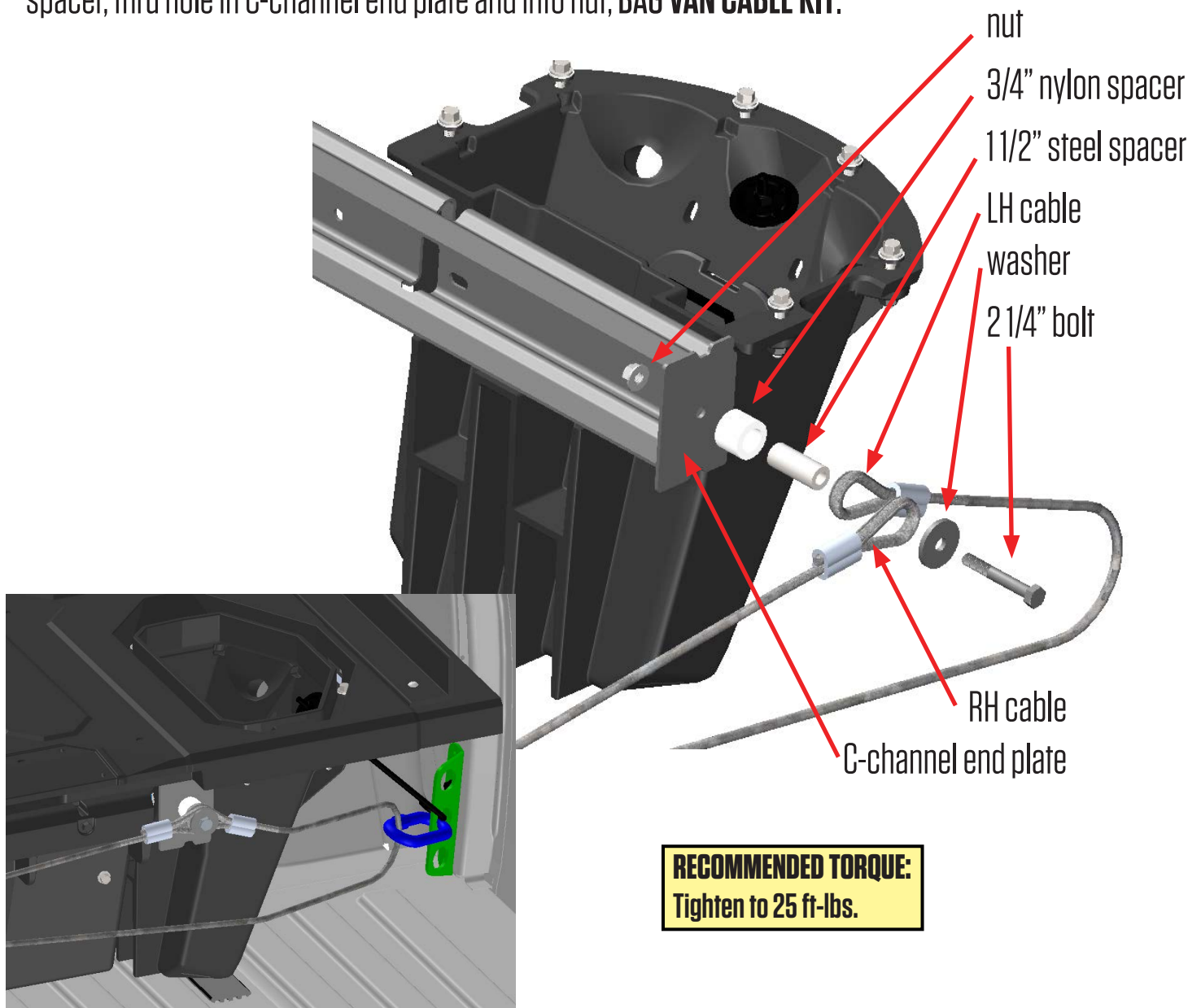

RETENTION CABLE INSTALLATION

Enlargement of LH cable assembly attachment to connecting link (blue).

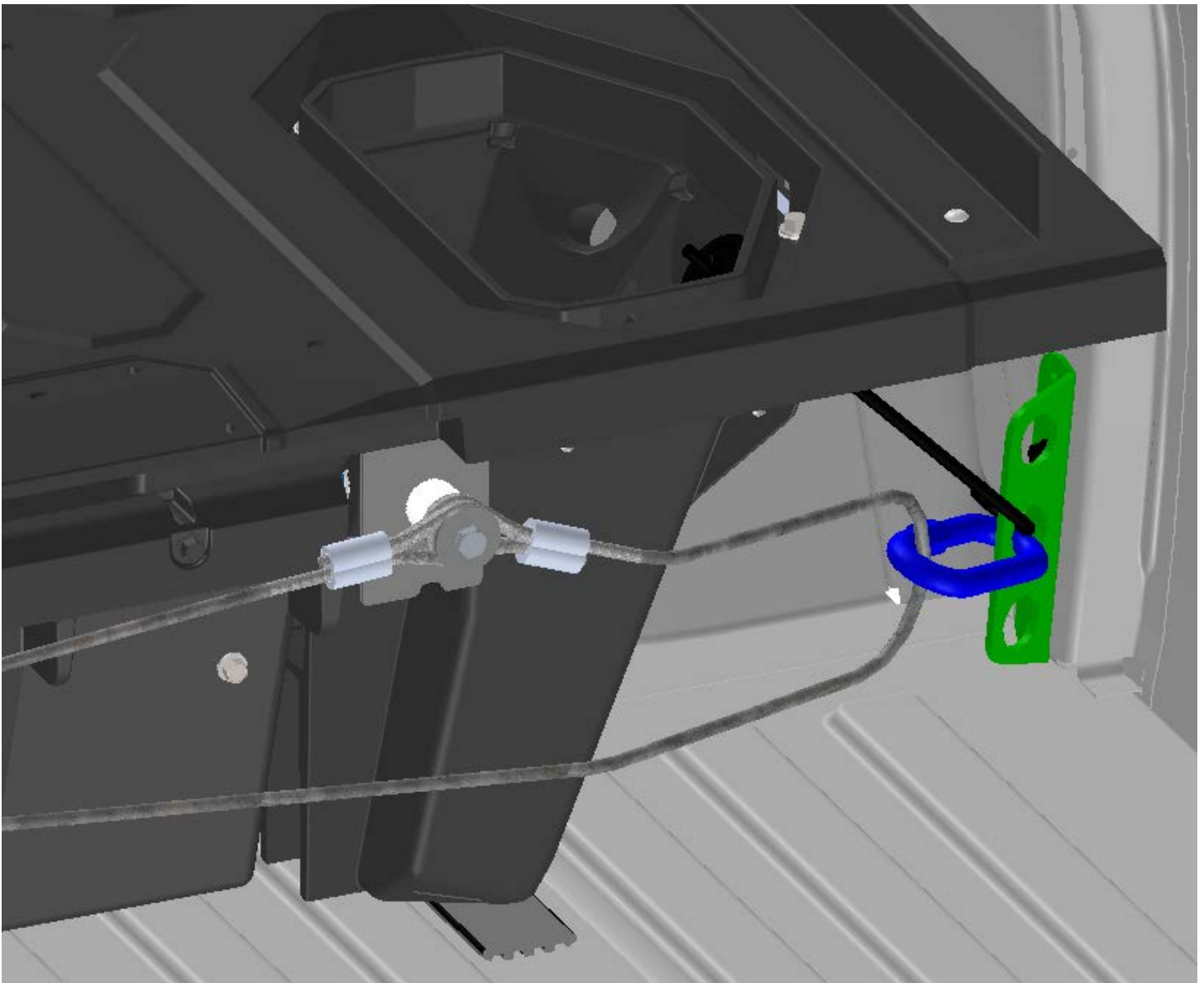
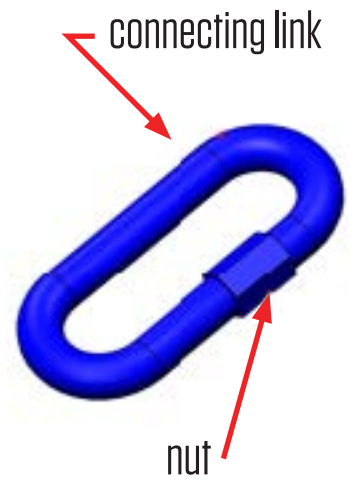

RETENTION CABLE INSTALLATION

Cable Installation – Step #3 –

Please note: the cables are of different lengths and marked LH & RH. The LH cable is longer.

- Loosen connecting link nut (shown in blue in assembled view); **BAG VAN CABLE KIT**, and install through center hole in mounting bracket (shown in green in assembled view). Tighten connecting link nut securely.
- Starting on the driver side of the vehicle, loop RH cable eye thru connecting link (shown in blue in assembled view); **BAG VAN CABLE KIT**.
- Assemble LH and RH cable ends in the order depicted in the exploded view image i.e. bolt thru washer, then thru LH cable eye and then RH cable eye, then thru 1 1/2" steel spacer and the thru 3/4" nylon spacer, thru hole in C-channel end plate and into nut; **BAG VAN CABLE KIT**.

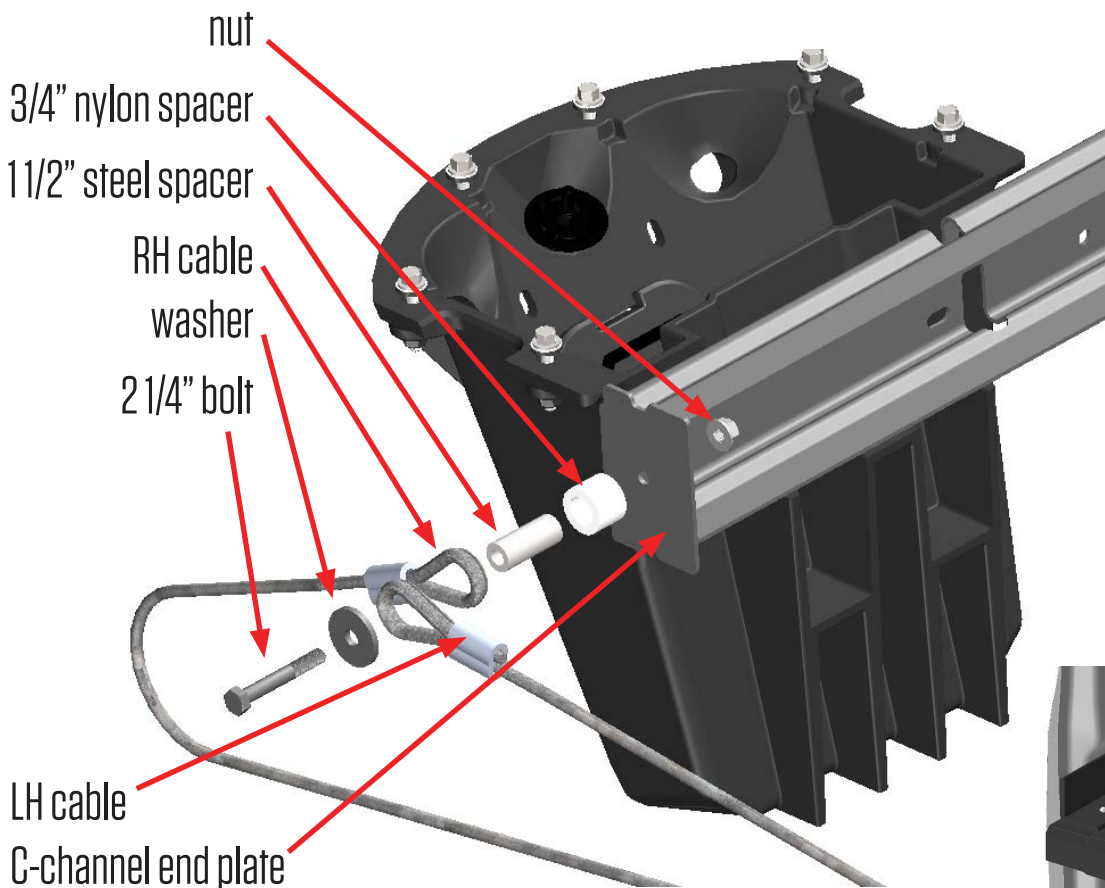

RECOMMENDED TORQUE:
Tighten to 25 ft-lbs.

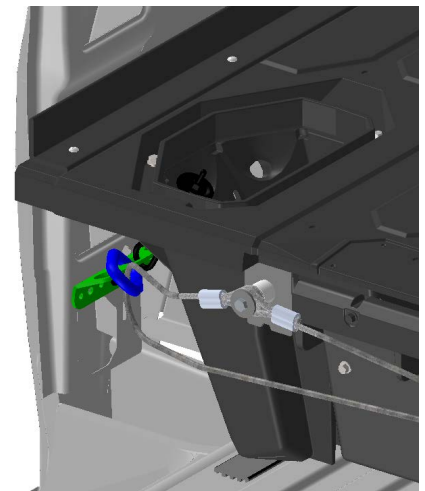

RETENTION CABLE INSTALLATION

Enlargement of RH cable assembly attachment to connecting link (blue).

